

Opal 840

MEFA Opal er en superflot postkasse, fremstillet i en ekstra kraftig og gedigen kvalitet og med et flot, stramt design.

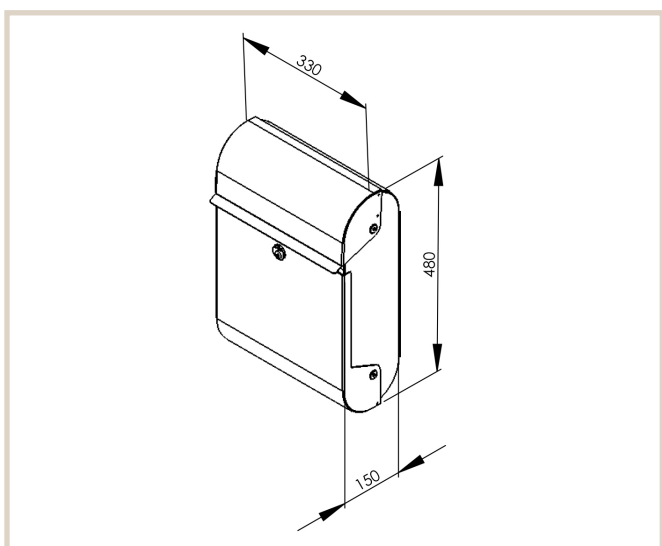

Tekniske specifikationer:

Højde: 480 mm

Bredde: 330 mm

Dybde: 150 mm

DB nr.

Hvid: 8131278

Sort: 8131286

Galvaniseret: 8131302

Rustfri stål: 5812037



Korskildeeng 6 - DK - 2670 Greve

info@renzgroup.dk

Telefon: 4619 3500

www.mefa.dk